

What a great **kitchen sink!**
 Two deep integral sinks, an integral drain board and a recess for a sliding cutting board.

MAXIMUS

Kitchen Workstation

ACCESSORIES:

- Sliding cutting board
- Sliding prep and rinse grate
- Removable perforated stainless grate for basin bottom (protects sink and glasses)
- MT-300 Extended Basket Strainer
- MT-200 Garbage Disposal Trim (extended throat)

DESIGN OPTIONS

	Vessel (above counter)
X	Integral - Standard Cabinet Install
X	Integral - Apron Front Install
X	Full Apron with drawer (farm sink)

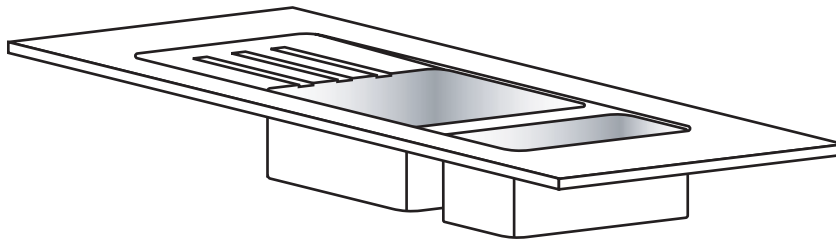

Integral

With a standard 1½ inch edge, the basin drops inside the cabinet and the basin becomes integral with the countertop. Countertop size is a custom option (up to 9' long), as is faucet placement.

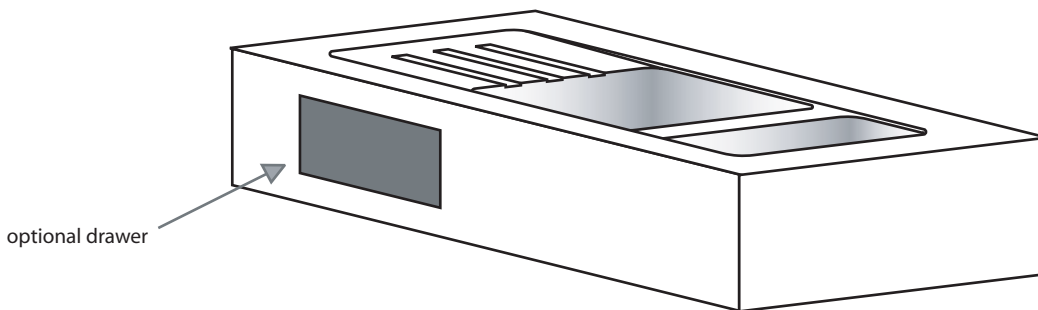

Full Apron with optional drawer

Maximus can also be one huge, deluxe farm sink. An optional drawer can be added to match the optional stainless steel sink bottom.

Kitchen Workstation

BASIN SIZE OPTIONS

Inside Dimensions

Outside Dimensions

Model	Length	Width	Depth	Drain	Length	Width	Depth
MAXI-1	31.5"	16"	8"	3.5"	34"	19"	9.25"

Dimensions are nominal within a tolerance of 1/8" +/-

PLAN VIEW

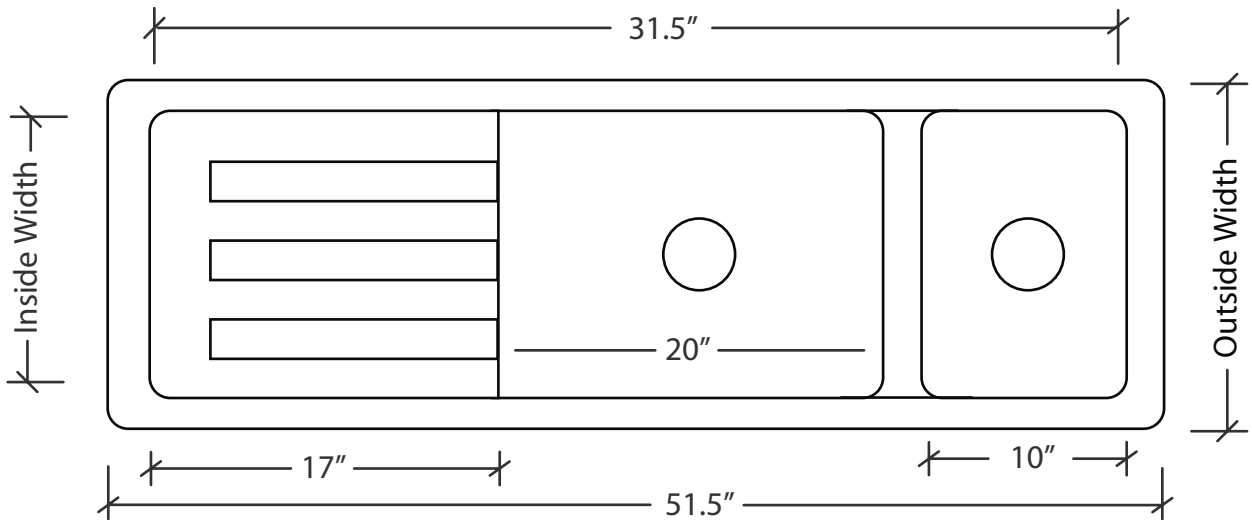

FRONT VIEW

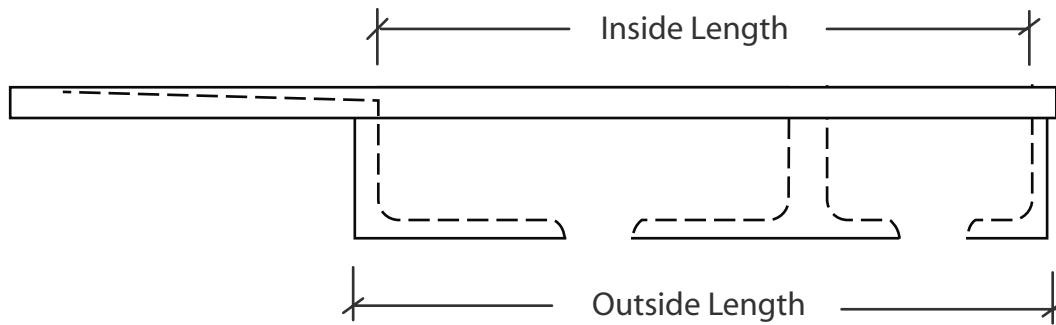

SIDE VIEW

